

MATLAB Simulation on Fuzzy PID Control to Feed Servo System of CNC Machine Tool

AK Madan, Aryaman Dubey, Gautam Singh

School of Mechanical Engineering, Delhi Technological University, Bawana Road, Delhi-42, India

Article Info

Article history:

Received 7 January 2021

Received in revised form

28 April 2021

Accepted 5 May 2021

Available online 15 June 2021

Keywords: PID Control, CNC Machine Tool, Fuzzy Logic Controller

Abstract: A CNC machine tool's feed servo mechanism is a dynamic electromechanical coupling system. It is difficult to correctly model the control mechanism due to the characteristics of time-varying parameters, load disturbances, and motor non-linearity. Intend to provide an approach where a fuzzy adaptive PID controller is designed by combining a PID controller with a fuzzy controller based on the mathematical model of the CNC machine tool fed servo system. Then intend to apply this controller to control the feed servo system to gain better control performance. The simulation results for the same are expected to show that this method not only has no static distortion, but also has a fast response with little overshoot, accounting for the high stability and accuracy of the fuzzy adaptive PID controller.

1. Introduction

Britain was the first to launch the industrial revolution in the 18th century. This era has been dubbed the "second industrial revolution" because of its accelerated industrialization. Around the turn of the nineteenth century. Electricity, railways, steel, mass manufacturing, and the automotive industry advanced quickly. The third industrial revolution occurs later, with the introduction of computers and digitized technology. Many people believe that are transitioning from the third to the fourth revolution, which is characterized by technical technologies such as robotics, biotechnology, 3D printing, AI, and IoT.

CAM (computer-aided manufacturing) is, however, a clear benefit of this new wave. It has also begun to have an effect on the construction, engineering, and other industries. This is the next best thing that happened during the modern machinery period, mostly for the sake of packaging. The global CAD market is projected to expand at a CAGR of 7% or more by 2020, thanks to the growth. Thus, this field offers ginormous ideas as well as areas for research purposes. In the coming area it is poised to influence every branch of engineering from Civil to Environment. All these benefits of this indispensable field drove us to do this MATLAB simulation.

2. Feed Servo System

The feed servo control system of the CNC machine tool is an error control system which is used with the PID control method traditionally. The PID controller is widely used in industrial process control and has achieved good effect due to its simple structure, easy control, and non- static error.

Traditional PID power, on the other hand, is typically used to control a linear process using a certainty model. The feed servo system's running state is dynamic, which accounts for its instability and instability model. Since, the feed system dynamics model is influenced not only by friction but also by disturbance torque factors, particularly when mechanical system damping, inertia, stiffness, and other parameters are considered, and the PID parameters are difficult to change.

For precision contour machining, an Adaptive Fuzzy Logic Controller (AFLC) is introduced, which changes both input and output membership functions at the same time. In a multi-axis CNC system core, a Genetic Algorithm (GA) can be used to tune the servo controller. Establishing a single variable speed loop self-tuning fuzzy logic with two inputs and three outputs for use as a location controller.

The GA can be used to optimize fuzzy control rules for the fuzzy-PID control system and the PID control parameters can be adjusted on-line. The advantages of this approach involve:

- Strong Robustness
- Less Sensitivity to the parameters of controlled objects
- Small Overshoots

Corresponding Author,

E-mail address:

All rights reserved: <http://www.ijari.org>

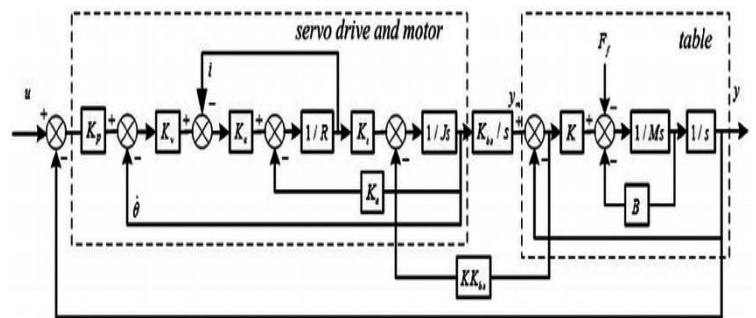

Fig.1: Feed Servo System

Thus, combining fuzzy control with traditional PID control to apply to CNC machine tool servo control systems would provide us with not only the flexibility and adaptability of the fuzzy control, but also with high precision characteristics of the PID control. Also, the controller parameters can adjust automatically in real time for the control object which has a non-linear, time-varying and random characteristics.

2.1 CNC system

A CNC machine tool usually includes the CNC system, feed servo system, worktable, and other parts. The feed servo system includes the AC servo motor, ball screw, linear guides, and measuring system. After receiving the control signal, the feed servo system transfers the work table rapidly and smoothly. In the automotive field, the Servo drive system is important because the system's motion accuracy has a direct effect on machine operation. The measuring system is made up of a location, speed sensors such as gratings, a pulse encoder, and an amplifier circuit. To gain closed-loop control, it employs position and speed feedback.

The motor rotates in a feed servo mechanism in response to a change in control order, and its angular displacement is translated to the desired linear displacement of the work-table by a mechanical transmission device with high-precision gears and precision screw-nut. Figure 1 illustrates the feed servo system's mechanical transmission and electrical control structure. Due to mechanical inertia, stiffness, friction, damping, and backlash, it is apparent that the servo system dynamic output requirements cannot be met solely by traditional PID control parameter tuning methods.

2.2 Device Transfer Mechanism

The device transfer mechanism is seen in Fig 1 as a relation with a fifth-order lag system that takes into account the various components of the servo system. The servo machine is converted to a second-order system to make the analysis easier. The transition feature of a servo device is as follows:

$$W(s) = \frac{K_N}{(T_N \times s + 1) \times s} \quad (1)$$

2.3 Adaptive Fuzzy Control Design

The fuzzy controller produces the control decision table on the basis of artificial control laws to decide the extent of control without learning the exact mathematical model of the controlled entity. Fig below demonstrates the configuration of the fuzzy adaptive PID control scheme. It shows that two parts of the conventional PID control and the fuzzy inference control constitute the framework. The error e and error change rate ec is regarded as input of the fuzzy controller, and the gain variation ΔK_p , ΔK_i , ΔK_d as output variables.

Centred on fuzzy control principles, the PID parameters are adaptively modified to satisfy the need for control parameters for various e and ec variables.

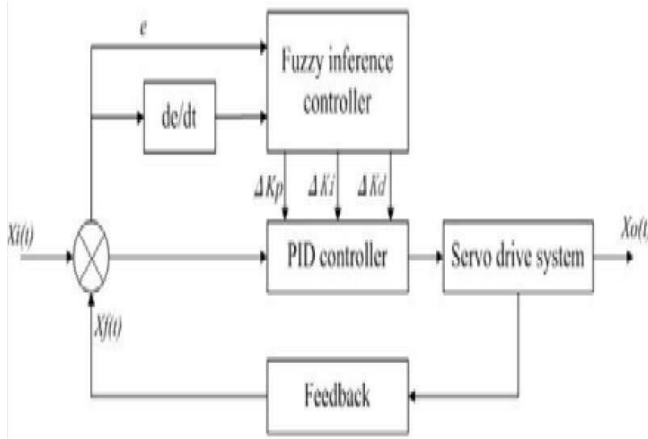

Fig. 1: Adaptive PID Control System Design Structure

The self-tuning PID parameters is calculated as follows:

$$K_p = K_{p0} + \Delta K_p,$$

$$K_i = K_{i0} + \Delta K_i,$$

$$K_d = K_{d0} + \Delta K_d.$$

Here, K_{p0} , K_{i0} , K_{d0} are the initial value of PID parameters, ΔK_p , ΔK_i , ΔK_d are the output of fuzzy controllers, K_p , K_i , K_d is the final control output parameter values.

2.4 Mamdani Fuzzy Systems

The 'Mamdani' type of controller being used here. The Mamdani fuzzy inference method was proposed as the first attempt to regulate a steam engine and boiler system using linguistic control rules acquired from professional human operators. But it can be used in feed servo system of CNC machine tool too. The method that has to be set in this type of controller, should be fixed to 'min'. Similarly, implication methods is set as "min", aggregation method is set "max", defuzzification method is selected "centroid". For both input and output variables, the triangular membership function is chosen. The domain is $[-6, +6]$, and fuzzy set is $\{NB, NM, NS, 0, PS, PM, PB\}$.

$$U(k) = K_p e(k) + K_i \sum e(k) + K_d ec(k)$$

Where, $e(k)$ is error and $ec(k)$ is error changes, K_p , K_i , K_d are characterized parameters being indicated proportional, integral and derivative respectively. Proportional coefficient K_p plays the role of speeding up the response rate and improving system regulation accuracy.

This can be considered analogous to K_p in Control Systems. Although K_p is higher, the response of the system is quicker, the precision of the control is greater, but the overshoot is too general, or even creates system instability. The function of the K_i integral factor is to minimise error in the steady state. K_i is better, static error is reduced faster, but it can cause overshoot by a larger integral saturation.

The machine dynamics are influenced by the differential coefficient K_d , K_d is higher, the error shift may be inhibited, but the greater differential coefficient would extend the controlling time, decreasing the potential to anti-interference.

2.5 Self Tuning Theory Parameters

The self-tuning theory for the parameters of K_p , K_i , K_d is as follows, according to the performance characteristics of the device obtained by the parameters of K_p , K_i , K_d :

- If $|e|$ is large, K_p should be larger and K_d should be smaller in order to provide reasonable tracking output for the system. While, the integral solution to prevent a greater overshoot of device response. The operation should be minimal and K_i is normally 0.0.
- If $|e|$ and $|ec|$ are the centre, K_p should be smaller to both decrease the overshoot of the device response and maintain a certain response time. In this case, since it has a great impact on the method, K_i should be acceptable, K_d should be taken lower.
- If $|e|$ is low, K_p , K_i should be improved in order to make the machine have good steady-state efficiency. However, K_p should be sufficient in order to prevent the output reaction oscillation of the system around the fixed value and take into account the anti-interference potential of the system. When $|ec|$ is small, K_d should be larger; if $|ec|$ is large, K_d is small, the medium size is normally K_d .

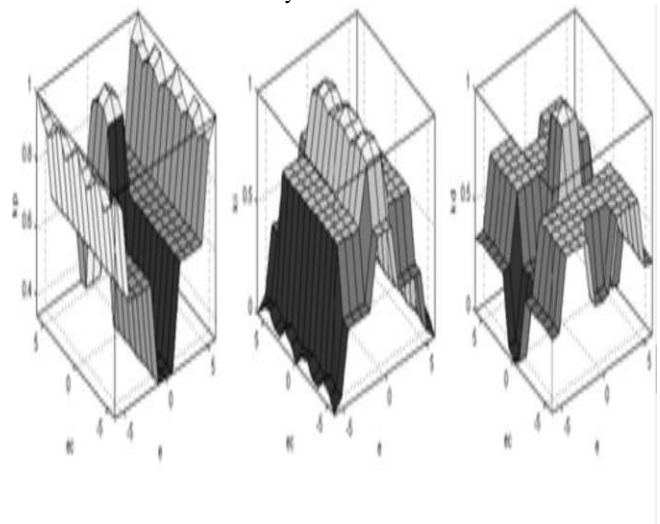

Fig. 2: rule of fuzzy control of the three parameters of K_p , K_i , K_d

3. Simulink Model

3.1 Fuzzy Adaptive PID Control System

The electromechanical transfer function used for the simulation has been determined based on the following parameters of a CNC machine tool.

- X-axis feed servo system
- $M = 1500\text{kg}$
- $H = 5\text{mm}$
- $L = 1.5\text{m}$
- $KB = 110\text{ MN/m}$
- $KN = 200\text{ MN/m}$
- $J = 0.01323\text{ kgm}^2$

The following are the parameters considered for the adaptive fuzzy controller:

3.1.1 Quantization Factors

- $K_e = 0.2$
- $K_{ec} = 0.1$

3.1.2 Defuzzification Factors

- $DK_p = 15$
- $DK_i = 0.1$
- $DK_d = 8$

3.1.3 Initial Values for the PID controller

- $K_{p0} = 30$
- $K_{i0} = 0.5$
- $K_{d0} = 15$

The following is the Simulink model of the proposed fuzzy adaptive PID control system with the above-mentioned parameters-

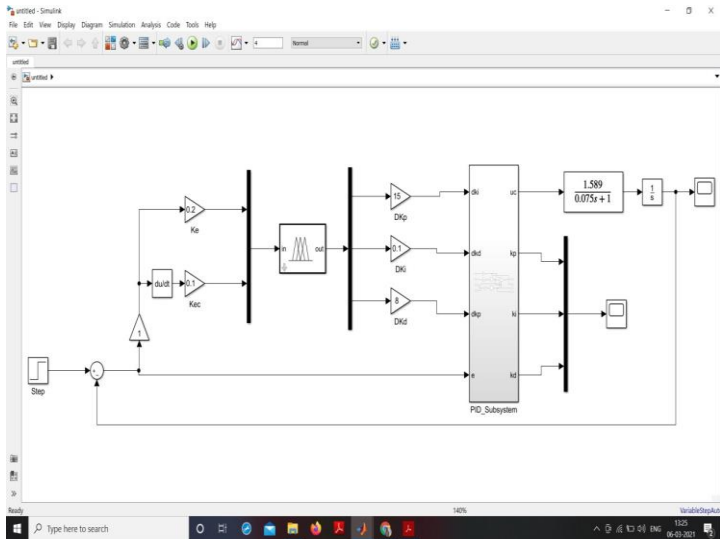

Fig. 4: Simulink Model

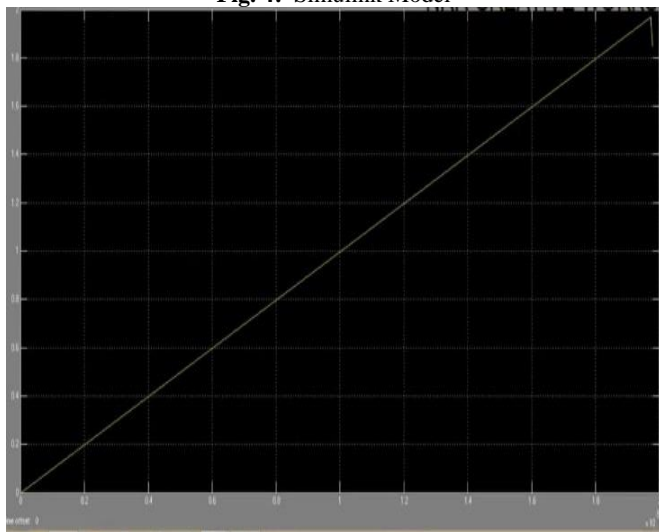

Fig. 3: Tracking by Adaptive Fuzzy Control

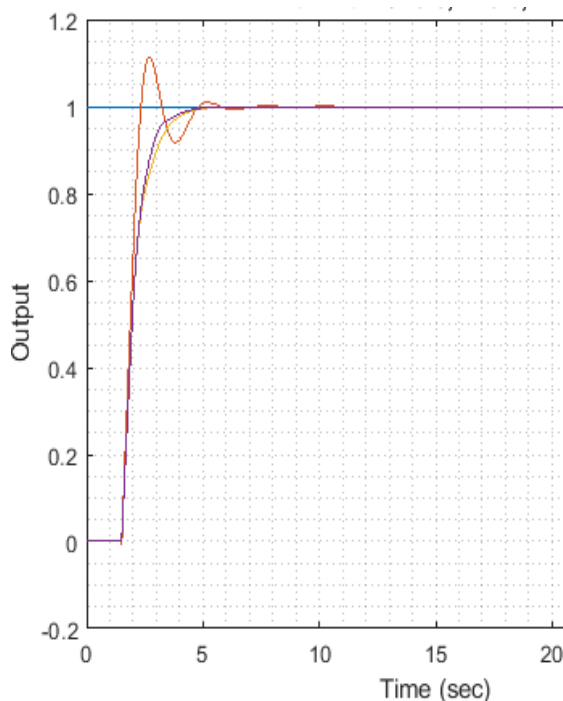

Fig. 4: Waveforms on Giving a Step Input

4. Results and Discussions

Compared with the conventional PID control, the fuzzy controller can correct the three parameters, ΔK_p , ΔK_i , ΔK_d online according to the system error e and the error change rate etc. The output of the above simulation came out. This shows effective position tracking by the adaptive fuzzy control. On giving a step response to the fuzzy control and the conventional PID control individually obtained the following curves:

- a) Reference
- b) PID Control
- c) Fuzzy Control

It can be observed that the adaptive PID controller can get a better system dynamic response with a small overshoot amount, high precision, steady-state, better-adaptability, and robustness.

The control theory of a feed servo system based on fuzzy PID control is presented in this article. The developed fuzzy PID control is applied to a CNC feed servo device, which takes into account electromechanical coupling effects as well as the mechanical feed connection. The three PID controller parameters can be auto-tuned online using calculated error and change rate of error.

The simulation and experimental results show that using a Fuzzy PID controller can reduce the difficulty of model construction; additionally, a good control can be achieved directly based on experience without a model; the fuzzy-PID controller has higher robustness than a conventional PID controller for a wide range; and the fuzzy-PID controller has higher robustness than a conventional PID controller for a wide range.

5. Conclusions

This study analyzed the control theory of the feed servo system based on fuzzy PID control. Based on this design, a fuzzy PID control applied to the CNC feed servo system by the virtue of an electromechanical coupling effect. One advantage of the controller is that it can be auto-tuned online for the three parameters of the PID controller by measuring error and change rate of error.

The fuzzy PID control has been compared with a simple and conventional PID controller on the step response, and all these results have suggested that the use of Fuzzy-PID controller can reduce the difficulty of model construction, alongside providing a good control with higher robustness over a wide range than the conventional PID controller. Also, a more rapid response with higher accuracy has been observed by the Fuzzy-PID controller.

References

- [1]. XP Liu, XS MEI, XT Wu. A Fuzzy-PID Controller for Self-Tuning of a Feed Drive System in CNC Machines. Mechanical Science and Technology, 23(1), 2004, 40- 43.
- [2]. DP Atherton. PID controller tuning. IEE Computing & Control Engineering journal, 4, 1999 44-50.
- [3]. DW Clarke, PJ Gawthrop. Source: Self Tuning control 126(6), 1979, 633 – 640 .
- [4]. Servo parameter tuning for a 5-axis machine center based upon GA rules. International Journal of Machine Tools & Manufacture, 41, 2001,1535-1550.
- [5]. A Mastsubara, Y Kakino, Y Watanabe. Servo performance enhancement of high speed feed drives by damping control. Flexible Automation Conference, Ann Arbor, Michigan, 7, 2000.
- [6]. K Nakaoka, T Sato. Feedforward controller for continuous path control of CNC Machine Tools, Advanced Technology R&D Center, Mitsubishi Electric Corporation 8-1-1 Tsukaguchi-honmachi, Amagasaki, Hyogo 661-8661, Japan
- [7]. J Altintas. Manufacturing Automation, 2000.-1.2,10.8,0.6,0.4,0.2,Y: 1.134,X: 0.207,Y: 0.8985,X: 0.8198,Y: 0.9923, Cambridge University Press 2000, 160-161.
- [8]. LY Kuo, JY Yen. Servo parameter tuning for a 5-axis machine center based upon GA rules. International Journal of Machine Tools & Manufacture, 41 2001, 1535-1550.
- [9]. S Jee, Y Koren. Adaptive fuzzy logic controller for feed drives of a CNC machine tool. Mechatronic; 14, 2004, 299- 326.

- [10].GY Chai, PB Zhao. The Study of Fuzzy- Immune-Adaptive-
PID Control in CNC Feeding Servo System. Modular Machine
Tool & Automatic Manufacturing Technique, 8, 2009, 74-77
- [11].J Ca. Development of a NC Servo System Based on Fuzzy
Adaptive Control, October 7, 2008, 314-319